

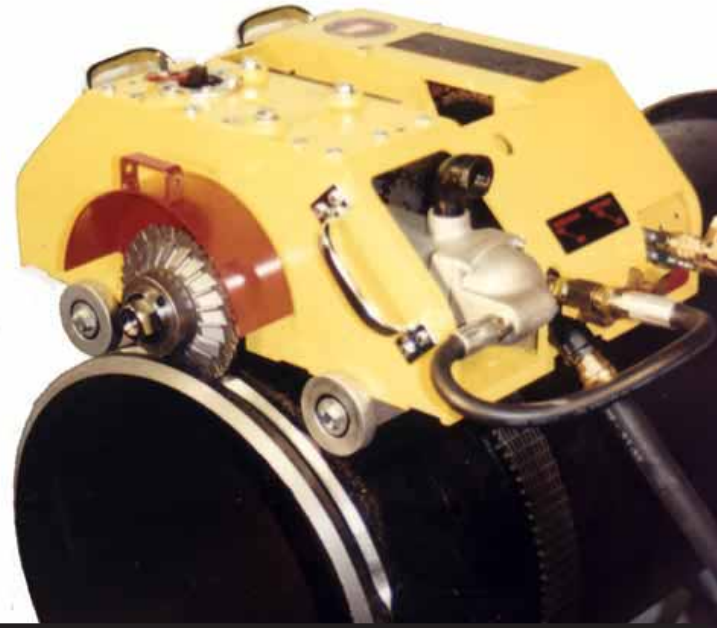

Trav-L-Cutter

Portable Milling Machine from **WACHS**

The **WACHS TRAV-L-CUTTER** is a portable milling machine capable of cold cutting and beveling simultaneously on all machineable pipe materials, pipe schedules and pipe sizes from 6" up to 72" O.D. Secured by it's own tensioning chain, the TRAV-L-CUTTER propels itself around the pipe, machining as it travels.



- **Safe, Cold Cutting**
- **Compact design, Easy Set-Up**
- **Corrosion Resistant***

Fast and Accurate

Cut and bevel standard wall pipe at 1 minute per inch of pipe diameter. Wachs high speed cutters remove 3/16" of metal while cutting, leaving the pipe end with a smooth, machined finish. Typical tolerances of up to 1/16" closure are normal.

The chain feed system maintains continuous out-of-round compensation while providing positive drive under all conditions for accurate cuts. By using an optional guide track and special guide track wheels, accuracy of .005" can be maintained even in zero visibility situations on all pipe sizes. This cutting method facilitates section removal in the field where new sections, pre-cut by the same method, can be easily dropped into place.

Operates Anywhere

In pneumatic or hydraulic driven models, the Trav-L-Cutter will operate on horizontal or vertical pipe, in the field or the shop, in a mud filled ditch or underwater, where it has been used successfully at depths of 600 feet.

All Pipe Diameters Including Tanks

Materials such as carbon steel, ductile iron, cast iron and most alloys in all pipe sizes from 6" to 72" can be cold cut and beveled simultaneously. Even tanks and vessels can be precision cut.



Hydraulic Trav-L-Cutters offer the inherent advantages of a completely sealed and self-lubricating closed loop system. The Model HE is particularly suited to field machining op-

erations under the type of hostile conditions often found on offshore drilling rigs, pipelines and on construction work in rivers and harbors.

Corrosion from constant exposure to salt water can be minimized with a stainless steel accessory package including special bearings seals and a high zinc coating.

Due to it's rugged construction, it is not unusual to find machines still operating after 10 or 20 years of severe service.

Safe and versatile

The Trav-L-Cutter can be used to machine materials such as carbon steel, stainless steel, ductile iron, cast iron and most alloys, in all pipe sizes from 6" to 72". It can tackle large tanks and vessels up to 33 feet in diameter. It is well suited for use in explosive conditions, like natural gas, crude product and fuel lines and has even been used to cut missile fuel cells. The Trav-L-Cutter can also be adapted to simultaneously cut off and groove pipe in one cut. Cutters are available for Victaulic and other grooved coupling systems.

**Model HE (Hydraulic) only.*

Trav-L-Cutter

Model E (Pneumatic), Model HE (Hydraulic)



Cutter Availability

Wachs supplies a wide variety of cutting blades to meet most applications. Most cutters are in stock and ready for overnight shipment. Please contact your local Wachs representative for availability. These include slitting blades for all pipe materials and schedules, beveling cutters for 37.5° and 30°.

"Due to its rugged construction, it's not unusual to find Trav-L-Cutters still operating after 10 or 20 years of severe service".

Slitting saws

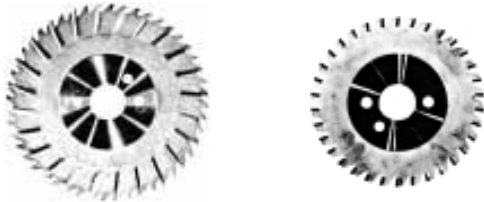

Bevel Cutters



Standard Equipment:

- Operating manual and isometric parts list
- Operating tools
- Spare Chain
- Connecting Pins
- Basic mounting chain for 6" dia. pipe
- Steel Storage Case
- 6' whip hose w/oiler (air only)

Optional Equipment:

- Additional chain for any dia. pipe
- Additional cutter blades
- Spray mist cooling system
- Halogen-free cutter coolant
- Reversible Feed Motor
- Guide Track and wheels to fit all pipe sizes up to 72" for vertical cutting multiple pass cutting or high accuracy cutting
- Long cutter spindle for use w/ grooving cutters
- Corrosion resistant package

SPECIFICATIONS

Machining Capacity:	6" thru 72" (153 to 1829 mm) pipe, large diameter vessels.
Cutter Drive:	Pneumatic: 4 hp governed air motor coupled with worm gearbox Hydraulic: As above, with hydraulic motor
Cutter Speed:	Pneumatic: 55 rpm internally adjustable from 35 to 55 rpm for use on work-hardened alloys Hydraulic: Adjustable 0-60 rpm
Feed:	Pneumatic: 3/4 hp air motor coupled through over load clutch, gearbox and chain reduction to final machine drive sprocket Hydraulic: 4 hp hydraulic motor
Feed Method:	Positive, nonslip chain drive
Air Requirements:	100 cfm @ 90 psi
Hydraulic Requirements:	15 gpm @ 1500 psi
Work Speed:	3" of surface feed per minute, max. (1" dia./min.). I.e. 10" pipe = 10 min. Over 1/2" wall as well as most alloys require reduced feed rate
Clearance:	10" -12" radial, 20" axial.
Controls (Model E & HE):	Cutter on - off, feed on - off, with interlock to prevent machine feed unless cutter is turning, adjustable feed control. (Model HE Only) Flow control valves. Separate controls provide adjustable spindle speed and cutter speed. Forward/Reverse valve governs machine travel direction.
Axial Feed:	.400" (10.16 mm) MAXIMUM
Weight:	Operating : 215 lbs., Shipping : 418 lbs.
Finish:	Paint
Dimensions (LxWxH):	24" (61 cm) x 20" (51 cm) x 10.75" (28 cm)

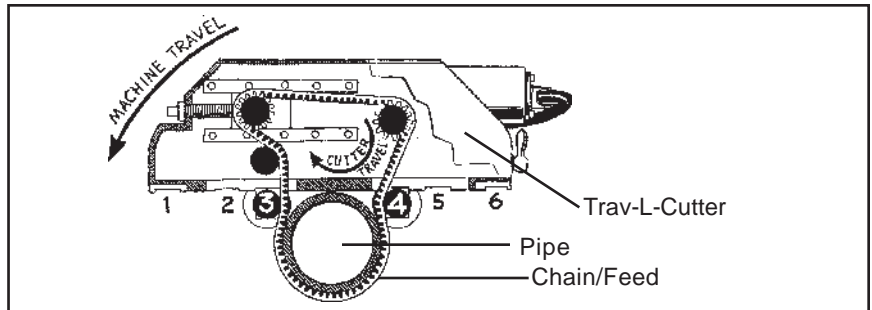

E.H. WACHS COMPANY

100 Shepard St., Wheeling, Illinois 60090

Fax (708) 520-1147

(847) 537-8800 Worldwide

(800) 323-8185 in the USA

Visit our website at <http://www.wachSCO.com>